

TYPE SL – 800 / SL – 850

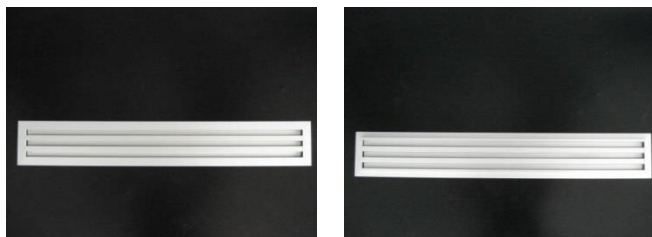

DESCRIPTION

The SL-801, SL-851, SL-802, SL-852, SL-803, SL-853 etc. diffusers are suitable for supply and extract air applications. The diffusers can be placed on false ceilings, ducts and walls and are available from one to ten slots. By adjusting the inner blades it is possible to obtain a horizontal distribution or a vertical projection of the air in one or two ways, without a change in the volume of air. The **SL-800** diffusers have a frame, while the **SL-850** diffusers are constructed for concealed fixing on the back of the plasterboard.

Their main characteristics are:

- Sliding blades adjustable from the diffuser face.
- Bearings and springs for the blades' support, preventing vibrations and noise generation.
- Volume damper built on each slot, adjustable from the diffuser face.

AVAILABLE TYPES

The **SL** diffusers are discerned in the following types, regarding the form of the inner blades:

- **SL** – Sliding blade.
- **SL-S** – Cylindrical blade.
- **SL-P** – Open-close blade. The blades are also used as volume dampers.

NOMINAL SIZES

The nominal height of the diffusers is related to the number of slots. The blades are placed parallel to the **first** dimension (length).

ACCESSORIES

- Volume damper for each slot. (**-D**)
- Perforated equalizing grid. (**-E**)
- The diffusers are available with 20 mm width frame (Type SL-800).

LINEAR SLOT DIFFUSER

INSTALLATION – FIXING

Each diffuser has counter punched holes and is delivered with flat-head, self-drilling screws, powder coated in the same RAL colour as the diffuser. For concealed installation for the SL-800 type the frame has no holes.

AIR FLOW CONTROL

The air throw pattern can be altered by adjusting the blades from the diffuser face. The air throw can be arranged horizontally and vertically.

The volume damper can be easily regulated from the face of the diffuser.

MATERIALS

Frame and blades: Extruded aluminium anodized in matt silver or powder coated in RAL colour.

Bearings: Polypropylene resistant up to 45°C.

Volume damper: Aluminium.

Screws: Galvanized steel (DIN 7504).

SPECIFICATION TEXT

Supply air slot diffuser consisting of fixed outer blades and adjustable inner blades from anodized aluminium, suitable for altering the air throw pattern horizontally and vertically. The number of slots (outer-inner blade couple) is a function of the air flow rate per meter length.

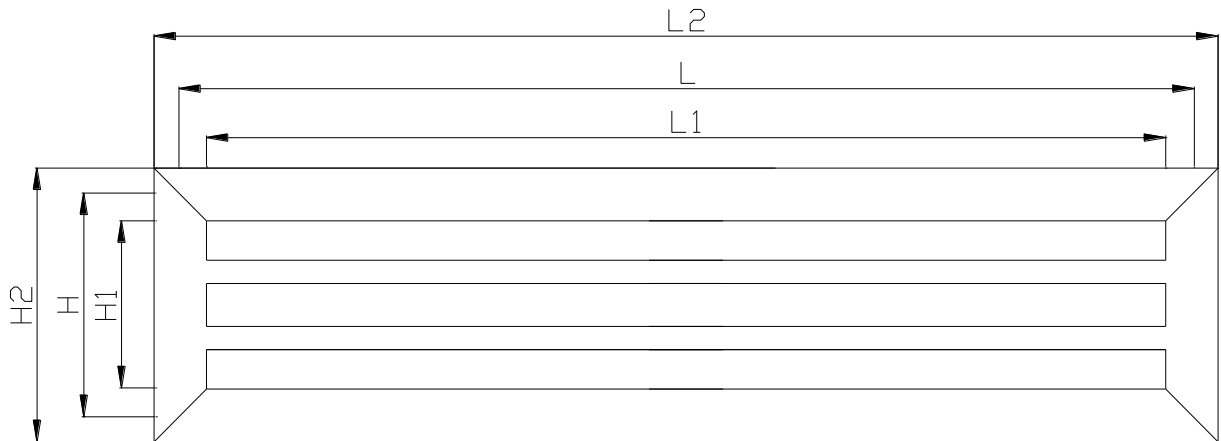

SL-800 – VIEW

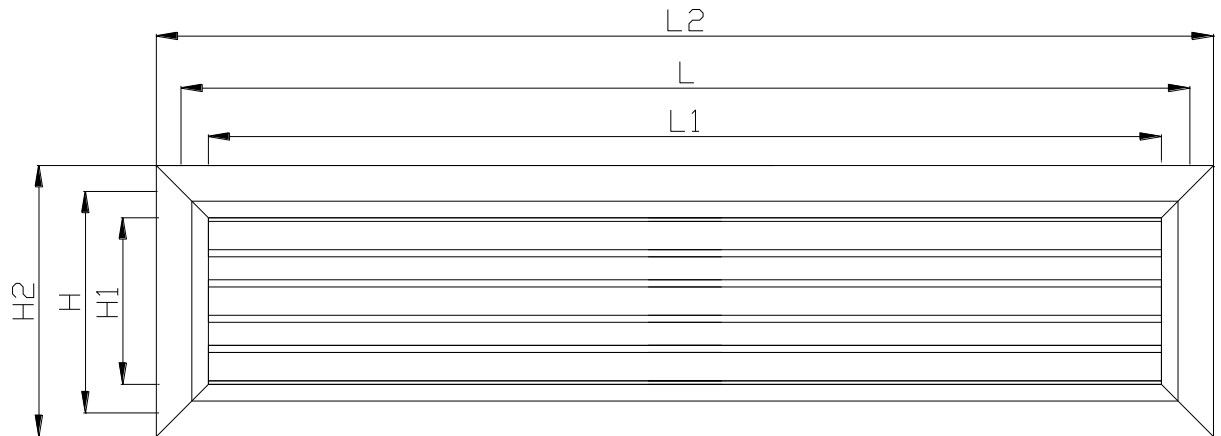

SL-850 – VIEW

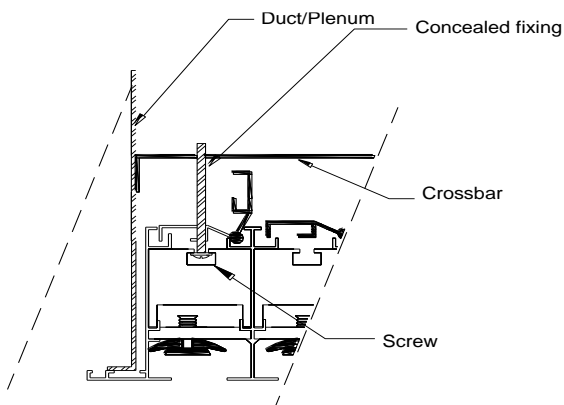

SL-800 – CONCEALED FIXING DETAIL

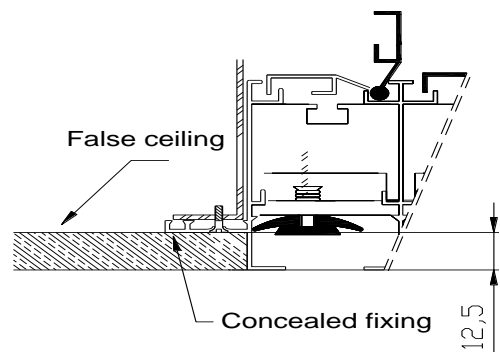

SL-850 – INSTALLATION DETAIL



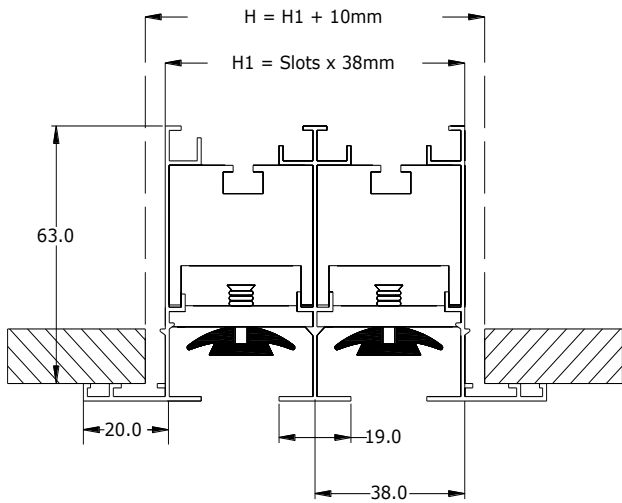

SL-802 – SECTION

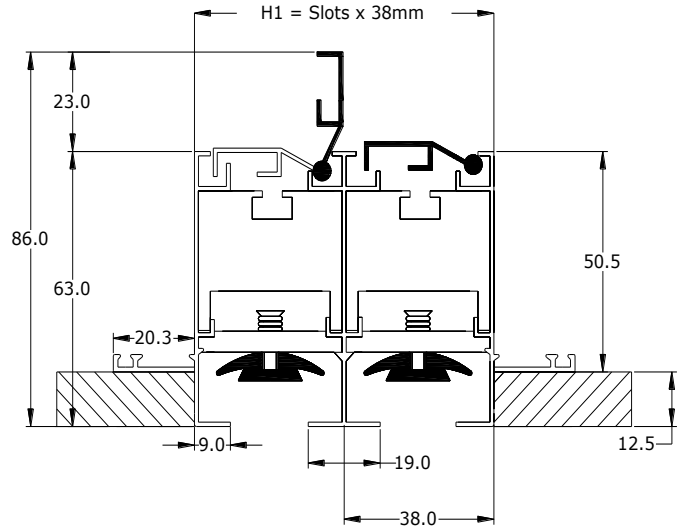

SL-852D – SECTION WITH DAMPER

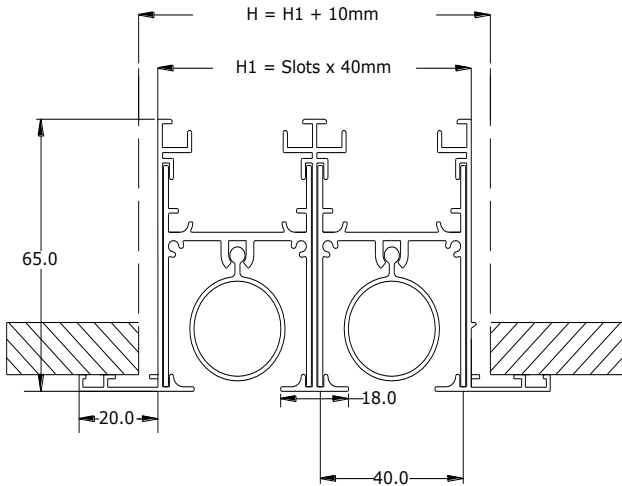

SL-802-S – SECTION

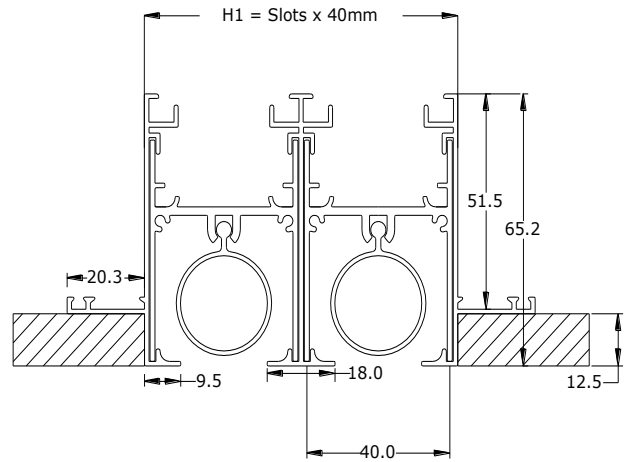

SL-852-S – SECTION

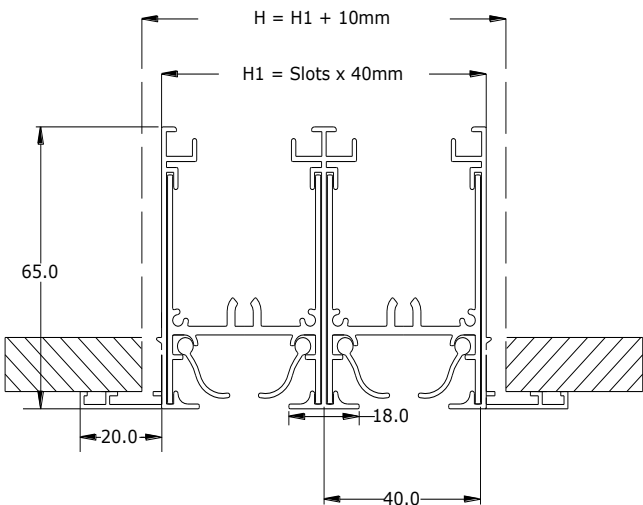

SL-802-P – SECTION

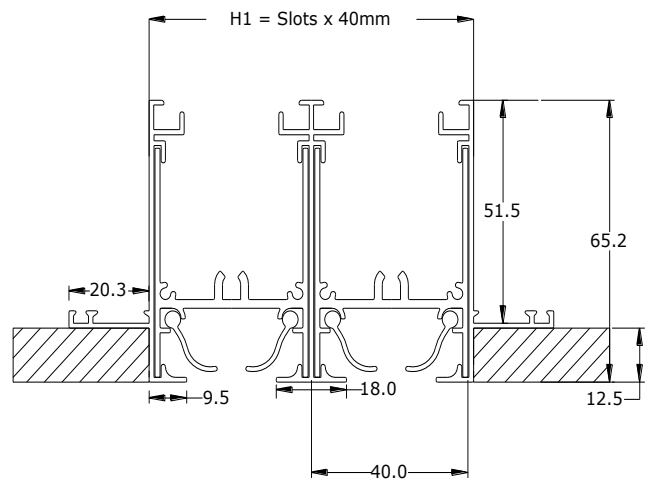

SL-852-P – SECTION



AIR FLOW THROW PATTERNS

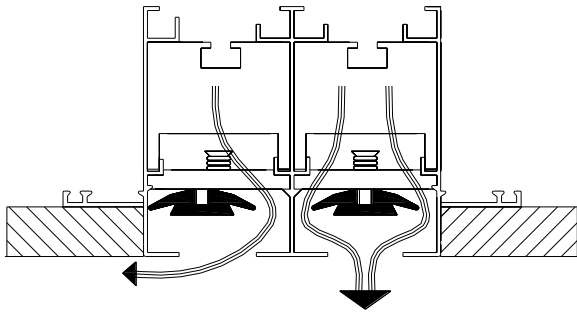

SL-852

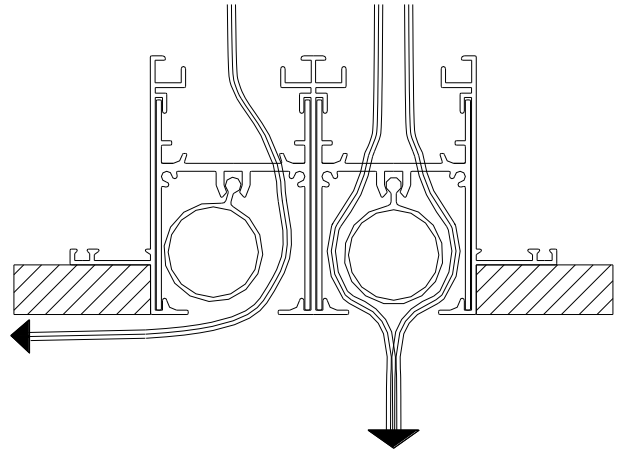

SL-852-S

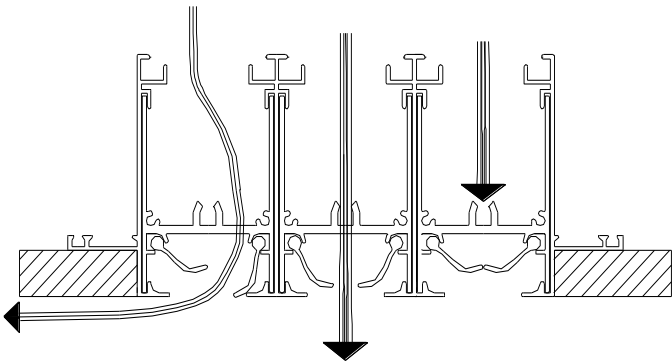

SL-853-P

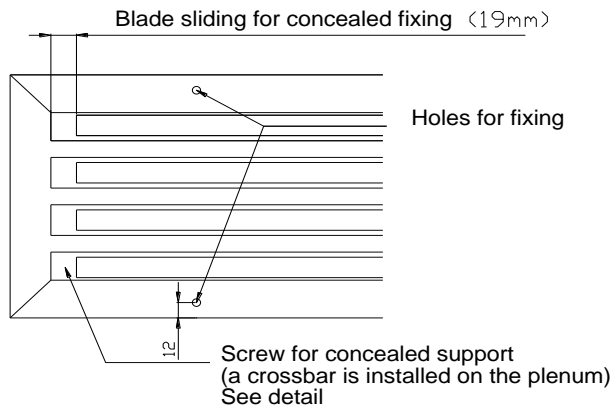

SL-800 – FIXING DETAIL

	Number of slots	1	2	3	4	5	6	7	8	9	10
Nominal height (mm)	SL-800 / SL-850 (No Slots x 38mm)	38	76	114	152	190	228	266	304	342	380
	SL-800-S / SL-800-P (No Slots x 40mm)	40	80	120	160	200	240	280	320	360	400
Opening/ plenum dimension (mm)	SL-800 / SL-850 (No Slots x 38mm) + 10mm	48	86	124	162	200	238	276	314	352	390
	SL-800-S / SL-800-P (No Slots x 40mm) + 10mm	50	90	130	170	210	250	290	330	370	410

- L : Nominal length – horizontal dimension
 H : Nominal height – vertical dimension
 L₁ : Length L₁ = L – 10mm
 H₁ : Height H₁ = H – 10mm
 L₂ : Overall length L₂ = L₁ + 2B
 H₂ : Overall height H₂ = H₁ + 2B
 B : Frame width. Typical 20 mm.

NOTES

- When ordering, refer first to the dimension parallel to the blades.
- Volume damper is available for all types.
- The diffuser comes with counter punched holes and self-drilling screws in the same RAL colour.
- The number of holes are two (one on the right and one on the left) for grilles up to 250 mm, and four (two on the top and two on the bottom) for grilles up to 1,500 mm. for grilles up to 2,500 mm the holes are three on the top and three on the bottom.