

TYPE D

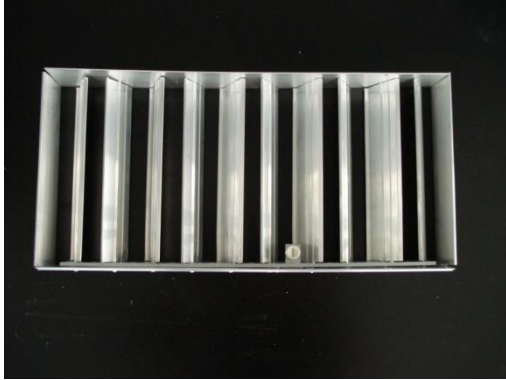

AIR GRILLE VOLUME DAMPER

SPECIFICATION TEXT

Volume damper for air grilles, consisting of parallel blades from anodized aluminium. The damper has a regulating screw or key to adjust the air flow.

DESCRIPTION

The volume dampers of the **D** series are suitable to use with all rectangular air grilles to regulate the air flow. It is constructed with movable opposed blades that can be adjusted in two ways:

- By means of a regulating screw on the front of the air grille.
- By means of a key on the front of the air grille.

Their main characteristics are:

- Blades from extruded aluminium, conjoined for synchronized movement.

NOMINAL SIZES

The **D** volume dampers are available in any combination of dimensions to meet the needs of the project.

We highlight that:

- The order dimensions are the dimensions of the **air grille**.
- The blades are placed parallel to the **first** dimension of the grille.

ACCESSORIES

- Regulating screw.
- Regulating key.

MATERIALS

Blades and frame: Anodized aluminium.

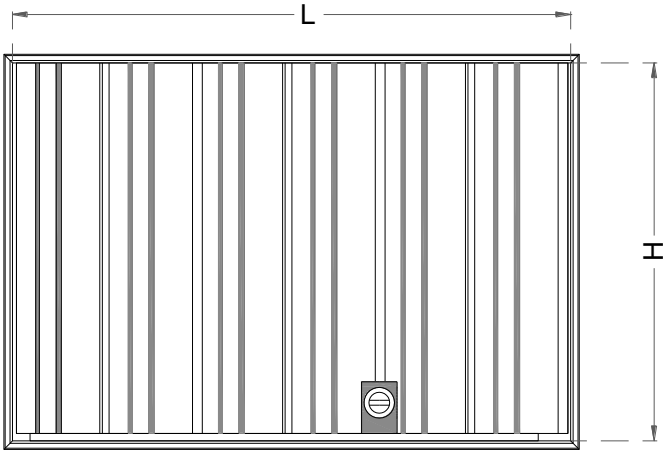

D - VIEW - REGULATING SCREW

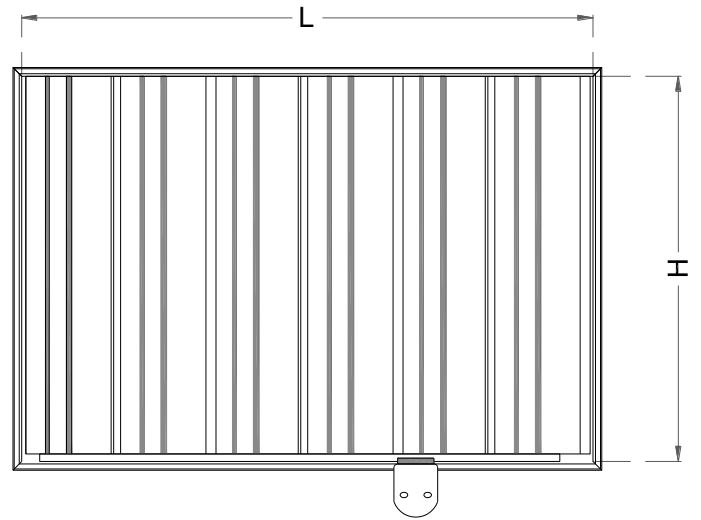

D - VIEW - REGULATING KEY

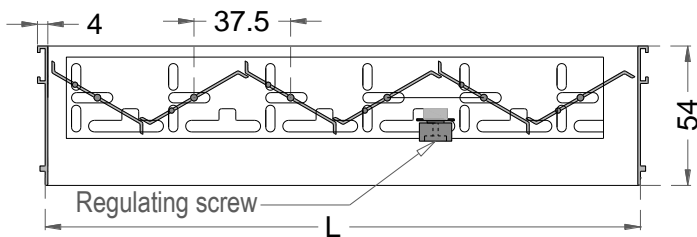

D - SECTION - REGULATING SCREW - CLOSED

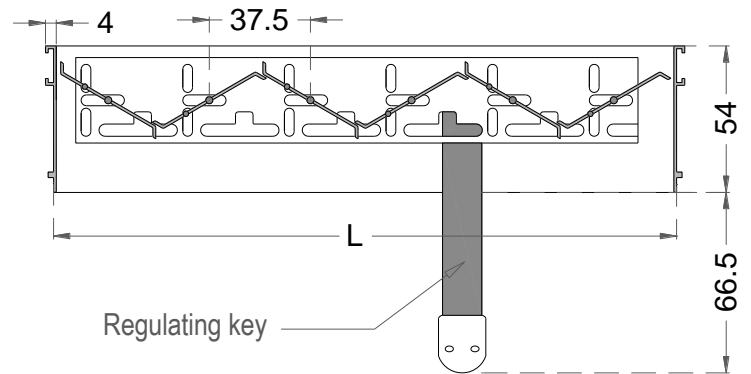

D - SECTION - REGULATING KEY - CLOSED

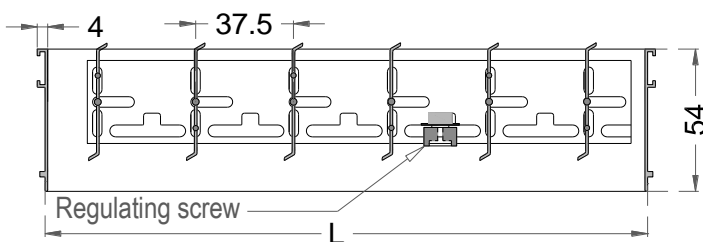

D - SECTION - REGULATING SCREW - OPEN

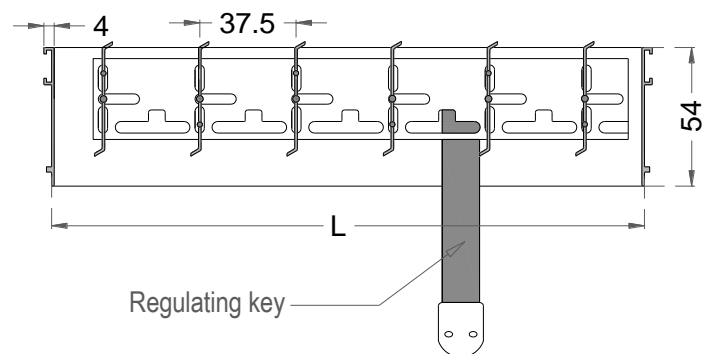

D - SECTION - REGULATING SCREW - OPEN