

## TYPE WR – 150 – A – F

## AIR GRILLE WITH ONE ROW OF FIXED BLADES ACCESSIBLE WITH FILTER



### DESCRIPTION

The grilles of the **WR-150** series can be easily opened for inspection and maintenance in HVAC installations. They are available with or without air filter.

Their main characteristics are:

- The basic features of every type counterpart the features of the **WR-150** series.
- Ease of opening for washing or filter replacement.
- The volume damper is adjusted to the fixed part of the grille; hence the grill cannot be used as an access door.

### NOMINAL SIZES

The grilles are available in any combination of dimensions to meet the needs of the project.

We highlight that:

- The order dimensions are the dimensions of the **opening**.
- The blades are placed parallel to the **first** dimension of the grille.
- Production codes: **(-A)** – Opening type  
**(-F)** – Filter

### ACCESSORIES

- Opposed blades volume damper, adjustable by an easily accessible key. **(-D)**
- Dust or grease filter. The dust filters are available in white **VILEDON** or net black **FCU** type. Grease filters are metallic. (See relevant brochure). **(-F)**
- The grilles are available with 32 mm or 19 mm width frame.
- A door handle can be placed on the grilles for ease of opening.

### INSTALLATION – FIXING

Each grille frame has counter punched holes and is delivered with flat-head, self-drilling screws, powder coated in the same RAL colour as the grille. For concealed installation, the frame has no holes.

### MATERIALS

Materials as in **WR-150** series.

FOR ORDER PURPOSE, THE FIRST GIVEN DIMENSION REFERS TO THE DIMENSION PARALLEL TO THE BLADES

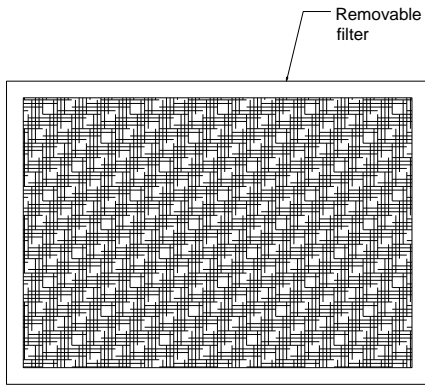

FILTER – VIEW

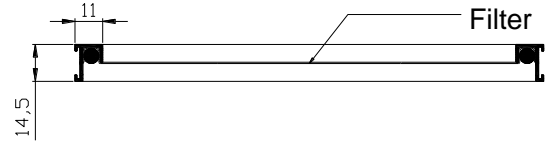

FILTER – SECTION

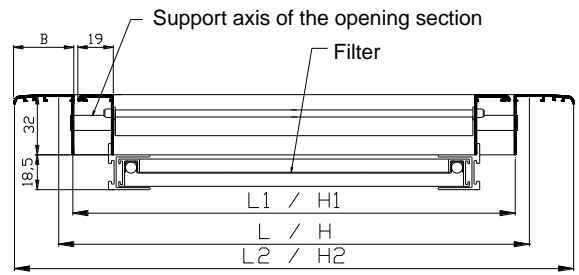
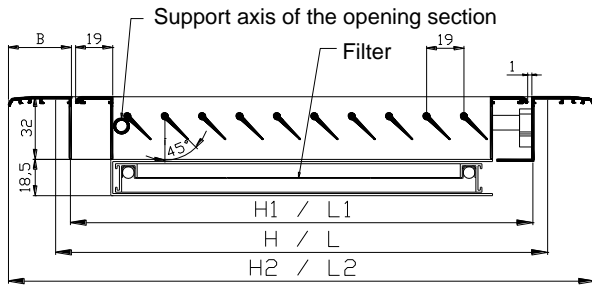

WR-150-A-F – SECTIONS

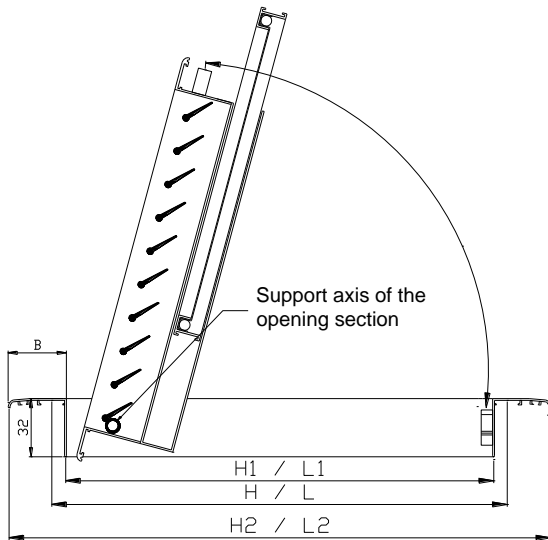

WR-150-A-F – SECTION

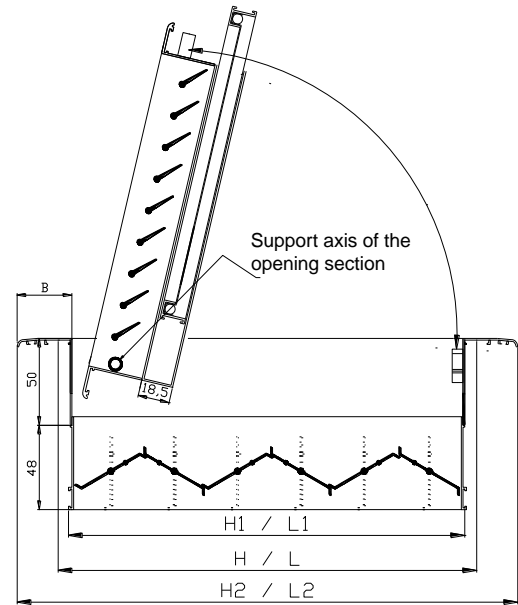

WR-150-D-A-F – SECTION WITH DAMPER

- L : Nominal length – horizontal dimension  
H : Nominal height – vertical dimension  
L<sub>1</sub> : Length  $L_1 = L - 10\text{mm}$   
H<sub>1</sub> : Height  $H_1 = H - 10\text{mm}$   
L<sub>2</sub> : Overall length  $L_2 = L_1 + 2B$   
H<sub>2</sub> : Overall height  $H_2 = H_1 + 2B$   
B : Frame width. Typical 32 mm. Optional 19 mm.

## NOTES

1. When ordering, refer first to the dimension parallel to the blades, i.e. for horizontal blades length is specified first and for vertical blades height is specified first.
2. Volume damper is available for all types.
3. The grille comes with counter punched holes and self-drilling screws in the same RAL colour.
4. The number of holes are two (one on the right and one on the left) for grilles up to 250 mm, and four (two on the top and two on the bottom) for grilles over 300 mm.